



Place
Date/Author

FreshBase Line

One Touch to In-Store Happiness

METTLER TOLEDO





Place
Date/Author

FreshBase Line

One Touch to In-Store Happiness

METTLER **TOLEDO**



Place
Date/Author

FreshBase Line

One Touch to In-Store Happiness

METTLER **TOLEDO**

Place
Date/Author



FreshBase Line

One Touch to In-Store Happiness

METTLER TOLEDO

1 Introduction

2 Functionality Overview

3 Applications

4 Models

5 Technical Data

6 Dimensions

7 Summary

Smarter Weighing with Touchscreen Convenience

- **Robust design.** High-Quality. Hard-wearing. Durable.
- **Easy operation.** Fast and intelligent. Intuitive via touchscreen. Step by step.
- **Rich functionality.** Powerful and secure FreshBase scale application with a wide variety of hardware options for service counter, sales, prepaking and self-service weighing.



Making Everything a Little Easier for Your Operators

- Weighing and serving made easy!
- Fast, precise and reliable
- Intuitive operation
- Touchscreen convenience
- Less burden on your service-counter employees
- Reducing stress and errors even at peak times



Making Everything a Little Easier for Shoppers

- Better in-store experience
- Faster weighing processes
 - At service counters
 - In self-service departments
- More relaxed, queue-free shopping
- Benefit from better service and advice
- Employees do have more time for them



Making Everything a Little Easier for You

- Faster weighing processes
 - At service counters
 - In self-service departments
- Less workload
 - Efficient data management
 - Flexible connectivity with existing IT systems
- Increase sales and optimize profitability of fresh food categories



Robust. Durable. Resistant.

Capacitive touchscreen – resistant to acids, fats and high mechanical use. Tempered glass protects from scratches.

Shock-resistant and imbued ABS polymer casing. Blade scuffs and scrape marks remain virtually invisible.

Anti-stick coating makes it easy to remove labels – important for self-service weighing

Solid aluminium die-cast casing, robust and yet lightweight.



Intuitive. Fast. Easy.



Tireless service due to adjustable anti-glare operator display. Capacitive Touchscreen combined with a clear navigation structure allow quick operations.

Best visibility and legibility under all lighting conditions due to 10.1-inch operator display and 7.0-inch customer display – both come with LED backlit technology.

Rapid roll change:
hassle-free and with
no wait times for
customers.

Feature-rich. Versatile. Compatible.

Versatile functions due to proven user interface and wide variety of equipment options (type of casings, displays, printer)

FreshBase scale application:

- Sales / self-service / prepacking
- Quick changing from e.g. sales to prepacking mode
- Options: vendor management, user rights management, promotions, 2 D barcode



Continuous. Easy integration. Flexible.

Easy integration in established processes due to extensive interface compatibility with METTLER TOLEDO scale application and network compatibility with METTLER TOLEDO scales

Highly compatible to existing integrations in tools and ERP solutions



Fast. Thorough. Hygienic.

Touchscreen and customer display have no gaps or edges where dirt could accumulate – this simplifies a fast and thorough cleansing.

Labels are easy to remove from the anti-stick coating – which is important when the scale is used for self-service.

Robust and easy-to-clean weighing plate made of stainless steel. Easily removable.

All interfaces are placed on the bottom of the scale – safe from dirt, moisture and damage.



Receipt, label and linerless printer options.

Easy accessible and therefore easy to clean print head.

No wait times, fast customer service thanks to printing speed of up to 125 mm/s.

Supports label rolls up to 120 mm in diameter – less roll changes are needed.

Fast and completely hassle-free roll changes.

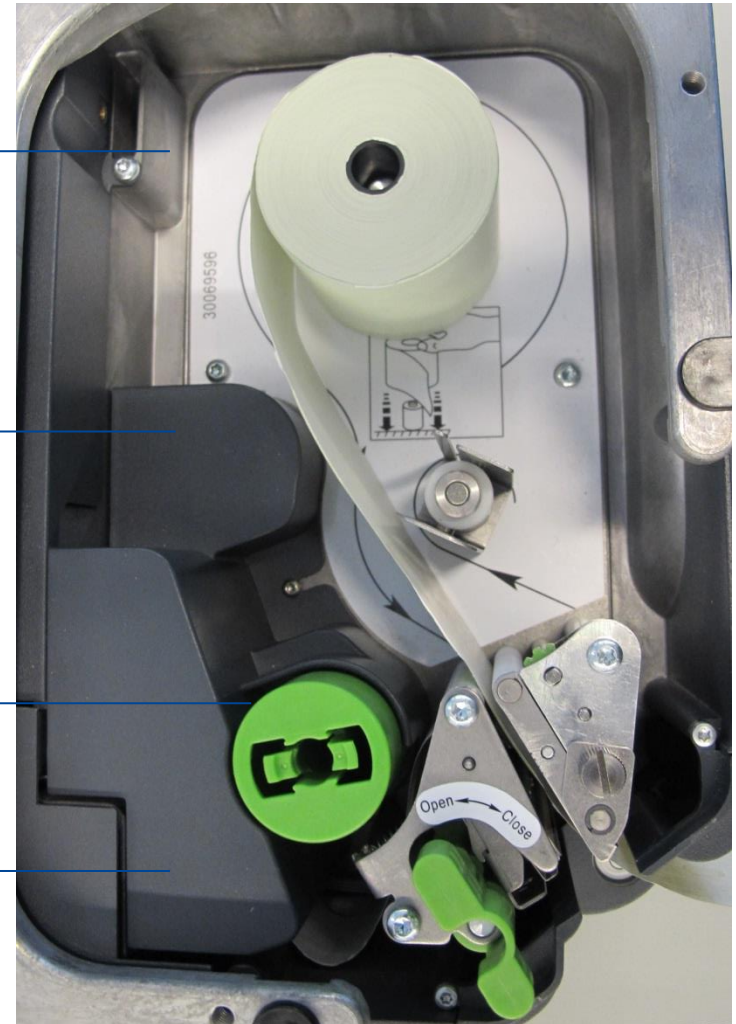

Receipt, label and linerless printer options.

- Advanced printing with reliable label delivery
 1. Practical printer clamp mechanism
 2. Innovative paper guide
 3. Useful spare paper-core storage
 - Long lifespan print head technology
 - Fast, high quality thermal printing (125mm/s, 203dpi)
 - Automatically identify loaded label size
- Reduce label size, simplify scanning and optimize print head life
 - Vertical barcode, small barcode, edge - edge / top - bottom
- Quick access to printer from the top for effortless paper replacement and cleaning
 - Less counter space required (no drawer)
 - Convenient plate storage
 - Short paper-feed path

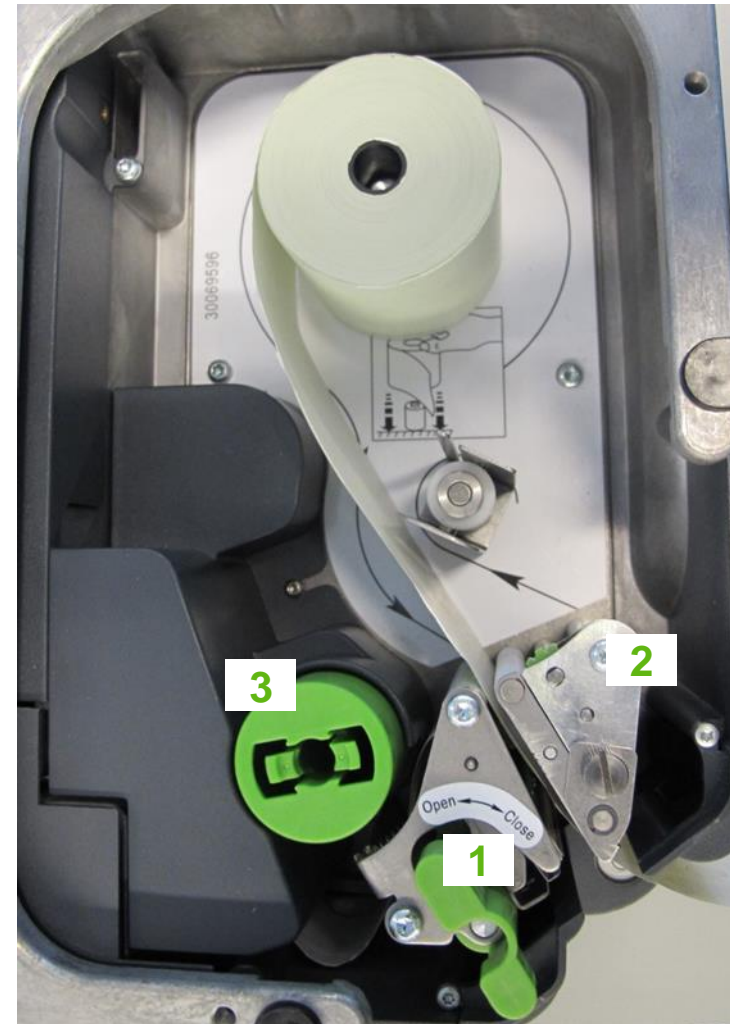

Versatile Interfaces. Protected Connections.

Versatile interfaces and protocols:
Ethernet, 2x serial RS232, 1x
RJ11 for controlling the cash
register drawer, 3x USB 2.0, 1x
USB OTG, integrated WLAN,
Audio output.

Interfaces placed on the bottom of
the scale, protected against dirt,
moisture and damage.

On/Off-button protected from being
pressed mischievously or
inadvertently.

Increased uptime, secure
connections because of cable
strain reliefs.



Easy, Flexibel and Secure. Over the entire Life-Cycle.

- Easy and simple scale management and maintenance over the entire life cycle with the powerful and intuitive Scale Manager application
- Embedded, though feature rich, scale application for best security at the POS.
- Simple data management with USB Mass Storage:
 - Simple data transfers from scale to scale
 - Updates of item data
 - Copy scale configuration
 - Firmware Updates
 - Backups/restore scale data
- Comprehensive network communication:
 - Stable and secure WLAN (optional)
 - Infrastructure
 - A dhoc (device to device)
 - Quick installation with DHCP for automatic IP setup

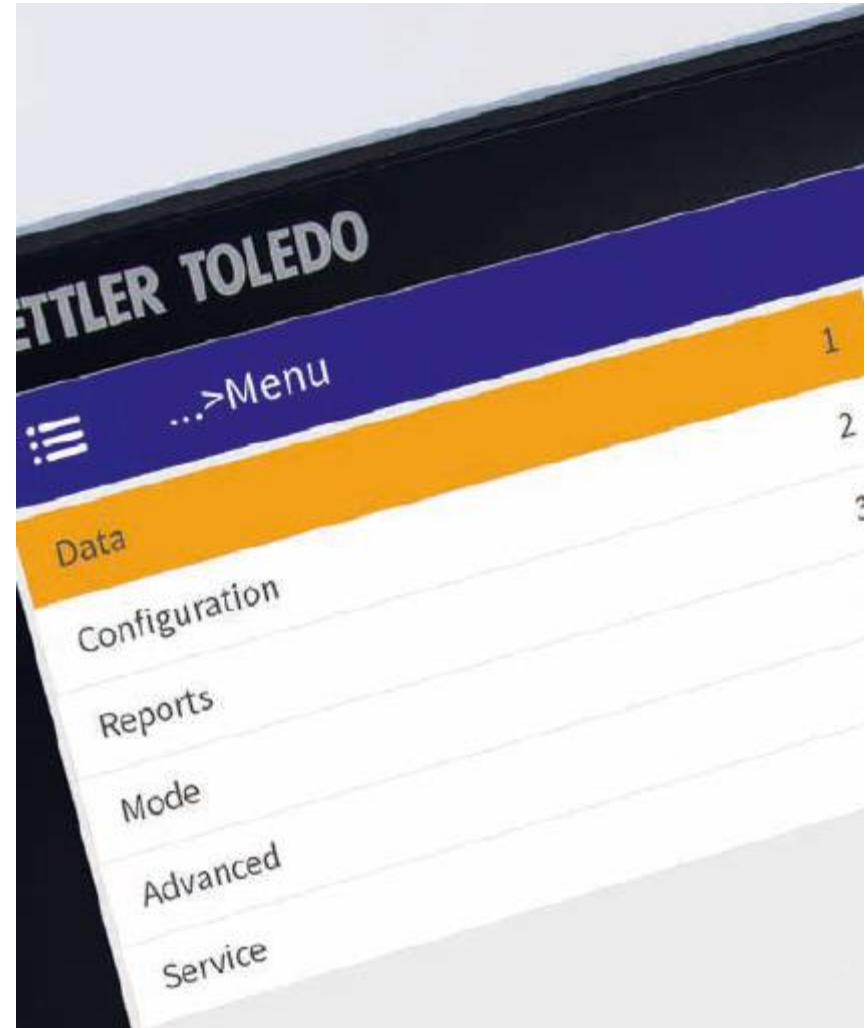

Quick and Easy Self-Service for Shoppers

- Intuitive, well structured self-service application
- combined with fast capacitive touchscreen operation
- allow shoppers to quickly find the right item, weigh and print a label.

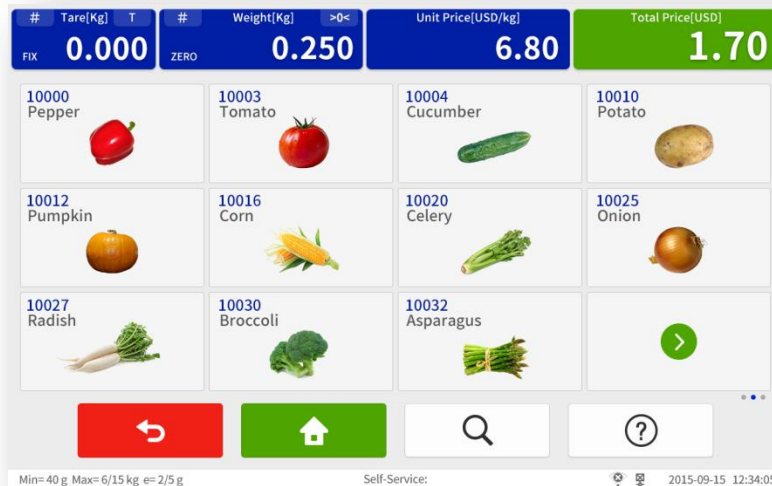
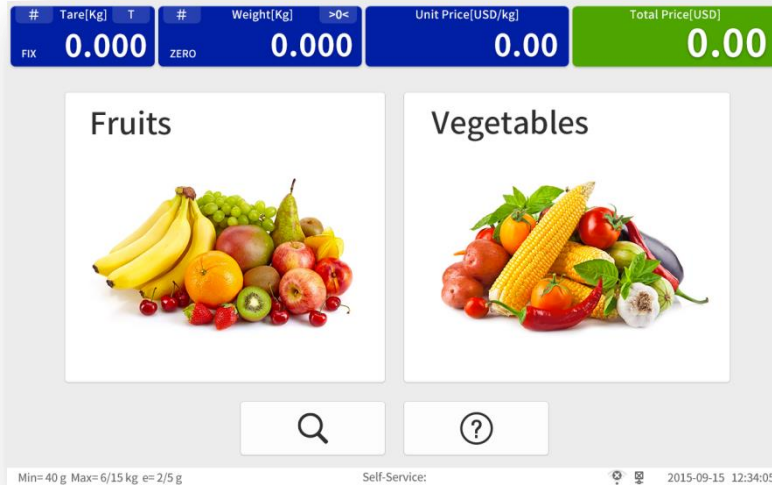

FreshBase at the Meat Counter



FreshBase at the Meat Counter



FreshBase at the Meat Counter



FreshBase at the Open Market



FreshBase at the Open Market



FreshBase for Self-Service Weighing in the Fruit & Vegetable department

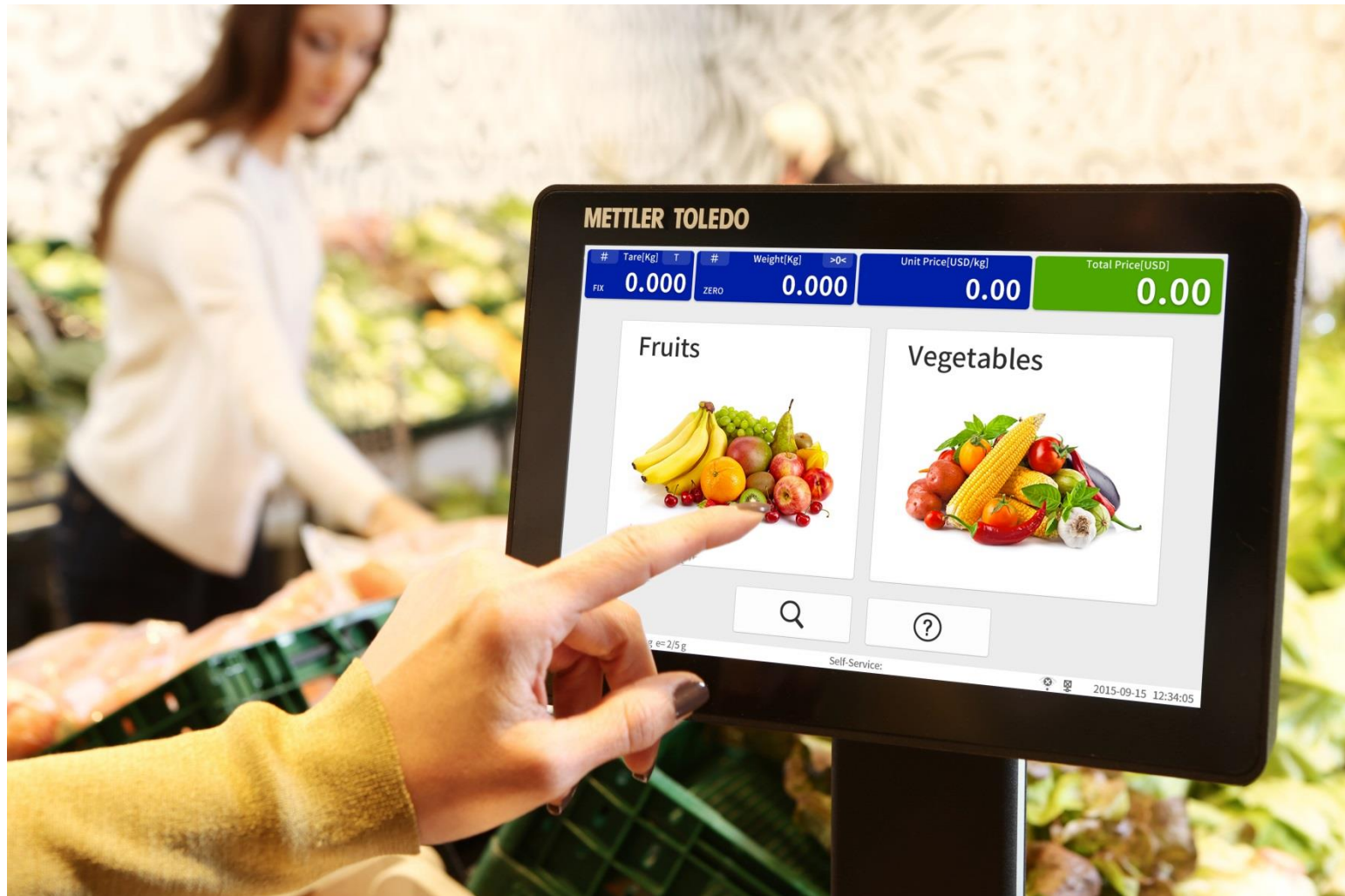

FreshBase for Self-Service Weighing in the Fruit & Vegetable department



FreshBase at the Cheese Counter



FreshBase – Smart Management



U2 model with customer display



C2 model with customer display



U3 model without customer display (self-service)



FreshBase Line

Operator Display

- 10.1-inch (25,6 cm) capacitive touchscreen in LED-backlit technology
- Screen resolution: 1280 x 800 pixel
- Tilt angle adjustable (stepless)

Customer Screen (optional)

- 7-inch (17,78 cm) customer screen in LED-backlit technology
- Screen resolution: 800 x 480 pixel
- Bracket for Scanner (optional)

Printer

- 2-inch label printer (56 mm)
 - Printing speed: up to 125 mm/s
 - Print resolution: 8 Dots/mm

Processor

- ARM® Freescale, 1.0 GHz

Data Storage

- 1 GB DRAM
- 8 GB onboard Flash

Interfaces and Protocols

- Ethernet interface (10/100)
- 2 x serial RS232 interfaces
- 1 x RJ11 interface for controlling the cash register drawer
- 3 x USB 2.0 connections
- 1 x USB OTG connection
- Integrated WLAN (IEEE 802.11 b/g/n Standard)
- Audio Output



Operating System

- MT Smart OS Embedded

Casing Colour

- Black (RAL 9005)

Weighing range*	3 kg/6 kg	6 kg/15 kg	15kg/ 30kg
Graduation	1 g/2 g	2 g/5 g	5g/10g
Min.capacity	20 g	40 g	100 g

* Not provided for all models

Dimensions in mm

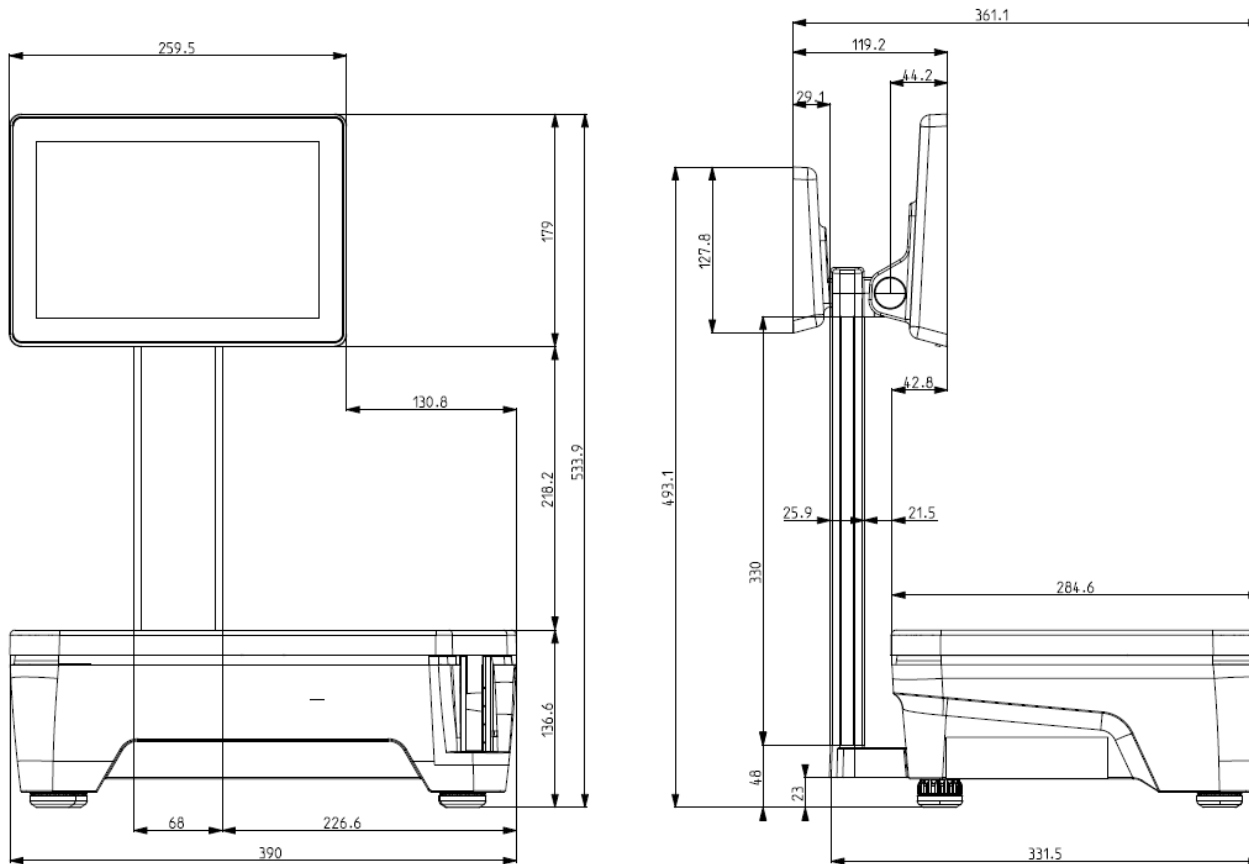

Dimensions in mm

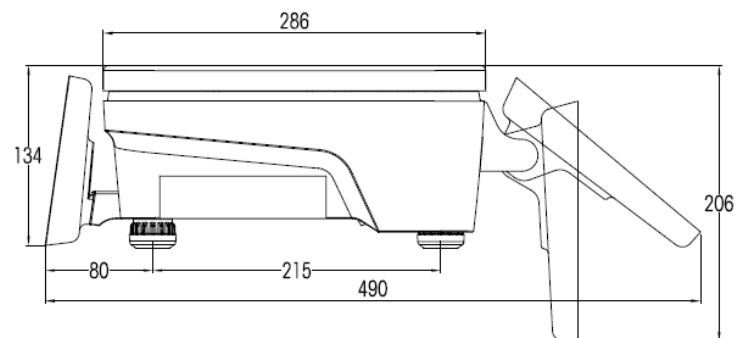
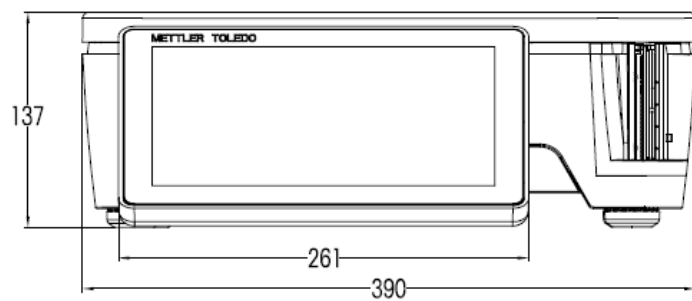

One Touch to In-Store Happiness

Making everything a little easier.

We call it "in-store happiness".

Watch the video and discover in-store happiness on:

► www.mt.com/FreshBase

